



Quality Access Doors- FAST!

SUBMITTAL/TECHNICAL DATA SHEET

DESCRIPTIONS

The KAWT Series Air & Water Tight Access Door is a durable, flush access panel designed for installation in walls and ceilings in applications where prevention of both air infiltration and water penetration is required. Featuring heavy-duty, 16 gauge, steel construction and 5 stage iron phosphate coating with a white baked, paintable enamel finish, door is perfect for environments such as clean rooms, hospitals, laboratories, operating rooms, pharmaceutical buildings, etc. where an airtight/water-tight seal is required.

SPECIFICATIONS

CONSTRUCTION:

- Frame shall be 16 gauge steel.
- Door shall be 16 gauge steel.
- Trim shall be 1.5" wide.
- Gasketing between door and frame shall be EPDM co-extruded trim-seal, which has a clamping range of 0.040"-0.118".
- All connected parts shall be continuously welded.
- Studs shall be stainless steel pan head phillips screws with self-retaining washers.
- Hinge shall be continuous piano hinge.
- Finish shall be prime coat of rust inhibitive electrostatic powder, baked white enamel. Stainless steel shall have No. 4 finish.
- Independently tested in accordance with ASTM E283/E283M, ASTM E331, and air infiltration testing result <0.1 L/s/m² (<0.01 cfm/ft²) when installed according to manufacture's instruction. Passed water penetration resistance test.

For a complete list of options visit www.BestAccessDoors.ca

SKU: **BAC-ATWT**

AIRTIGHT & WATERTIGHT FLUSH ACCESS DOOR



DIMENSIONS AND APPEARANCE

>> CLICK TO VIEW ADDITIONAL DETAILS AND PRICING <<

STANDARD SIZES (Special sizes on request)

DOOR SIZE W X H (IN.)	WALL/CEILING OPENING (IN.)	NUMBER OF STUD LATCHES	SHIP WT. (LBS.)
8 x 8	8 5/16 x 8 5/16	2	9.75
12 x 12	12 5/16 x 12 5/16	2	11.25
14 x 14	14 5/16 x 14 5/16	2	12.25
16 x 16	16 5/16 x 16 5/16	2	13.25
18 x 18	18 5/16 x 18 5/16	2	14.25
24 x 24	24 5/16 x 24 5/16	2	20.25
30 x 30	30 5/16 x 30 5/16	2	28.55
36 x 24	36 5/16 x 24 5/16	2	29.74
48 x 30	48 5/16 x 30 5/16	5	40.74
48 x 36	48 5/16 x 36 5/16	5	48.79

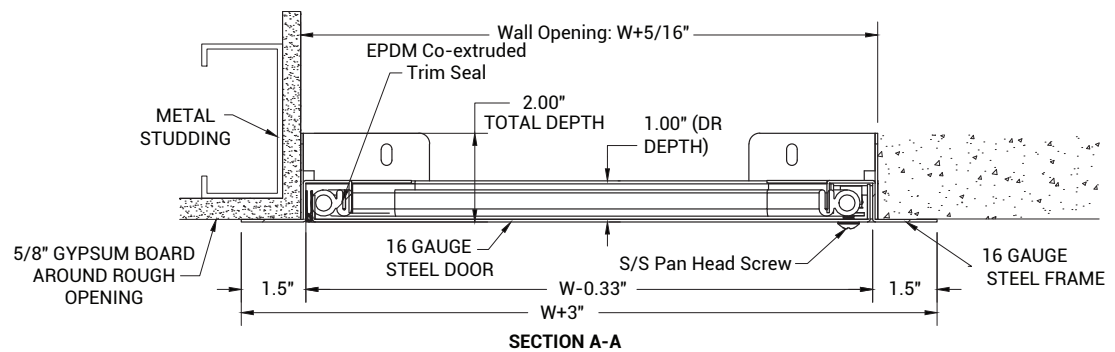
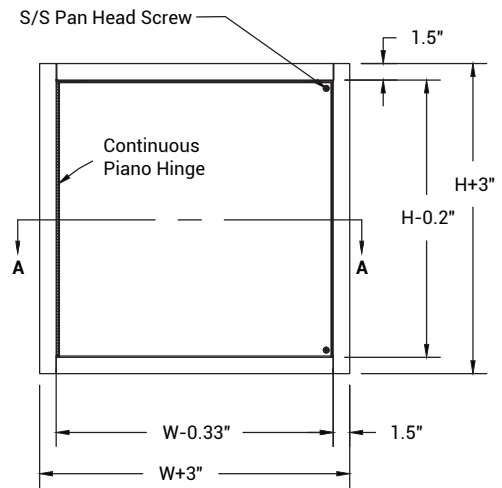

PROJECT DATA

Custom Sizes Available - Fast!

Scan or Click



To view Pricing and Additional Product Info.

PROJECT NAME :	QTY	W	H	OPTIONS
ARCHITECT :				
DEALER :				
CONTRACTOR :				
LOCATION :	SPECIAL INSTRUCTIONS :			
DATE :				
TAGGING INSTRUCTIONS :	SUBMITTAL APPROVAL : (signature or stamp)			

TELEPHONE:
1-800-483-0823

FAX:
1-888-828-6021

385 WILSON STREET EAST,
SUITE 302
ANCASTER, ON, L9G 2C1
CANADA



WEBSITE:
www.BestAccessDoors.ca

E-MAIL:
info@bestaccessdoors.ca